

BEFORE YOU START: Determine whether your spa will need a Top Mount or a Side Mount installation.

Look at diagrams on left and see which one best resembles spa type for installation.

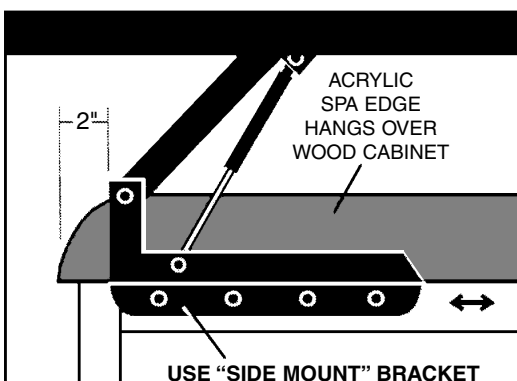
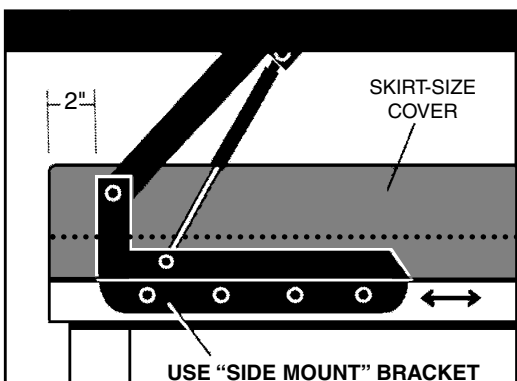
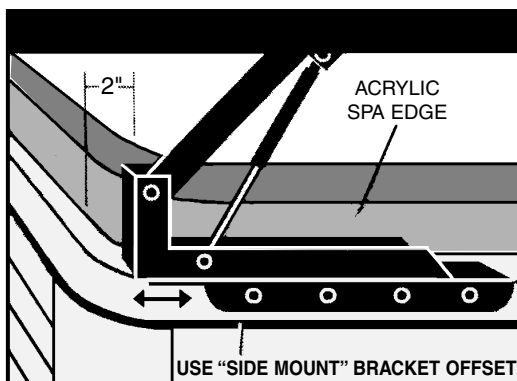
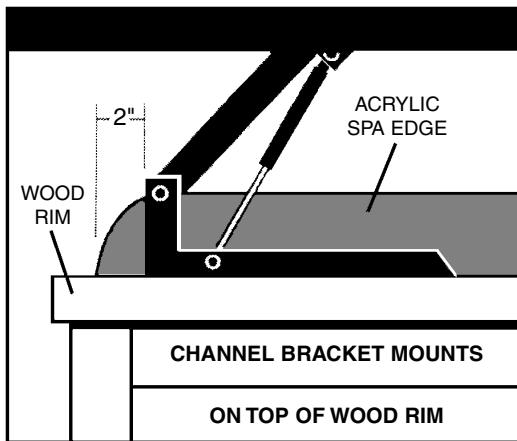

TOP MOUNT & SIDE MOUNT INSTRUCTIONS:

1. Attach Ball Stud to Channel Bracket using 1-Ball Stud and 1-Lock Nut (per side). Attach other Ball Stud to Pivot Arm using 1-Ball Stud and 1-Lock Nut (per side)
2. **-VERY IMPORTANT-** Position spa cover (in closed position) on spa. Position rear of Channel Bracket approx. 2 inches forward from back edge of spa cover. Make sure Channel Bracket is parallel to side of spa cover.
 - **TOP MOUNT:** Mount Channel Bracket to wooden spa rim using (4) 1¹/₄" Lag Bolts. (per side, pre-drill holes in wood rim). **See Fig. 1**
 - **SIDE MOUNT:** Align holes of SM (side mount) Bracket with Channel Bracket holes. There are 6 holes in top of SM Bracket and only 5 holes in Channel Bracket. You will use 5 or no less than 4 when connecting SM Bracket to Channel Bracket. **Fig. 3 & 4** (Offset Channel Bracket from SM Bracket using no less than 4 holes in order to reach within 2 inches of rear of spa cover). **See Fig. 2**
 - Mark hole position of SM Bracket on wood side. Mount SM Bracket to wooden spa side using (4) 1¹/₄" Lag Bolts. (per side, pre-drill holes in wood rim).
 - Mount Channel Bracket to SM Bracket with (5) 3³/₄" (No less than 4) Hex Bolts, and 5 Lock Nuts (per side). Lock Nuts are positioned on the bottom side of SM Bracket.
3. Slip covers over both ends of bars of Extension Arm before sliding arm bars in position on cover (**see next page**).
4. Attach Pivot Arm to Channel Bracket using (1) 1³/₄" Hex Bolt, (1) Lock Nut (per side) Lock Nut can be placed on the inside or outside edge of spa (as allowed by specific spa manufacturer). **DO NOT OVERTIGHTEN!**
5. Click "Latching" Gas Shock onto Ball Stud of Channel Bracket **ONLY** on most convenient side of spa (thick section to Channel Bracket and thin section to Pivot Arm), leaving shock laying down. Click "Regular" Gas Shock onto Ball Stud of Channel Bracket **ONLY** (thick section goes to Pivot Arm and thin section to Channel Bracket), leaving shock laying down.
6. With spa cover on, but off front 1¹/₄" way, slide Extension Arm bars in position on each side of cover (**There is a left & a right arm**).

Fig. 5

Front bar slides into middle of cover, while 2nd (top) bar lays on top of cover.

Fig. 6

Push cover from front slowly and evenly, keeping cover centered over spa. **Fig. 5**

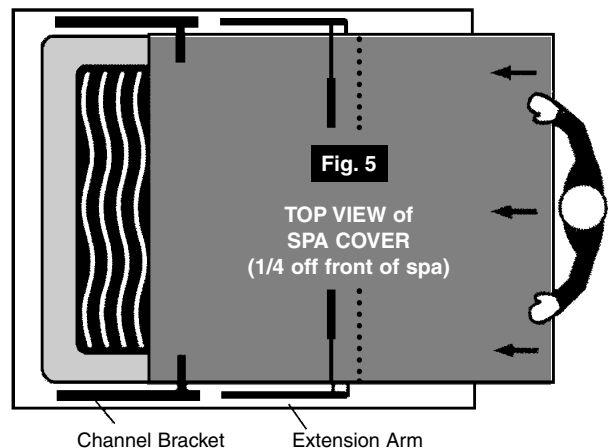

Fig. 6 - Spa with Cover 1/2 open



SHOWING POSITIONS OF EXTENSION ARM BARS & PIVOT ARM

Front bar slides between both halves when cover is closed. Exposed when folded back.

Top bar on top of cover. In between cover when cover is folded back.

EXTENSION ARM

Heat up cover with a hair dryer or use liquid soap to slip over metal easily.

Rest stabilizer bar (SB) on top of spa cover in between cover when cover is folded back.

- Turn (SB) parallel with pivot arm if rim of spa is over 5" in height.

PIVOT ARM

BALL STUD

"LATCHING" GAS SHOCK

#10 VERY IMPORTANT!
PUSH BUTTON ON LOCKING GAS SHOCK TO CLOSE COVER BREEZE. FAILURE TO DO SO MAY CAUSE DAMAGE TO COVER BREEZE OR COVER!

CHANNEL BRACKET

- Keep pushing cover evenly until Extension Arms slide into pivot arms. When cover is centered over spa (measure carefully on both sides)

See Fig. 5 Secure Stabilizer Bar AND Extension Arm to Pivot Arm using 5/8" Hex Bolt. If spa rim is greater than 5 inches, secure Stabilizer Bar parallel with Pivot Arm.

- Fold back front half of cover & manually lift cover to open position. Lift shock up & click on to Ball Stud on Pivot Arm (both sides).

- Attach Elastic Strap/Ball to front bar on Extension Arm. (Use to lower cover instead of pulling on spa cover).

HARDWARE CHART



BALL STUD

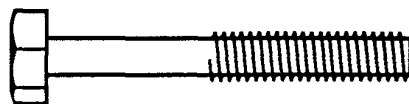

1 3/4" HEX BOLT

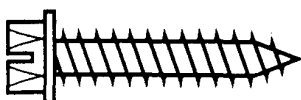

1 1/4" LAG BOLT

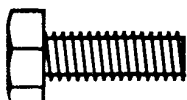

3/4" HEX BOLT

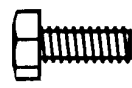

5/8" HEX BOLT



LOCK WASHER

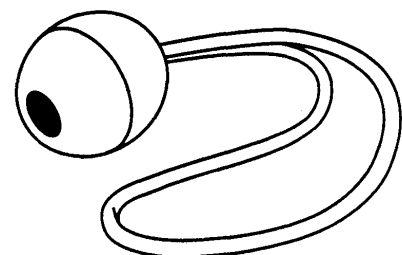

ELASTIC STRAP/BALL